

NORITSU

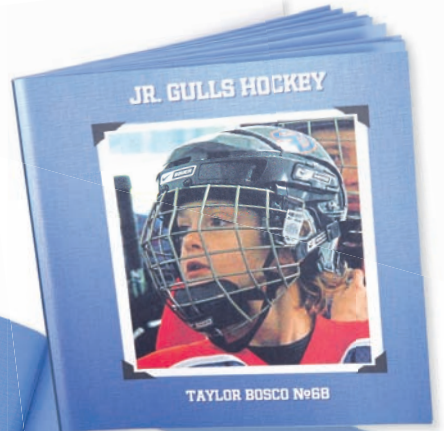

D502

the award winning
photo-quality **duplex** inkjet printer



Photo imaging is undergoing a dynamic change. The dramatic shift is the increased consumer's desire for **photo books**, calendars, greeting cards and personalized photo items.

It's really a **duplex** product opportunity. Research shows consumers want photo books. And duplex makes the photo books even more appealing. Far more than single-sided prints.

This is a real **game changer**.

Another big fact. Research shows that consumers are turning away from producing them at home or online. They are coming into **your store**, for **your help** and for your professional advice.

The **D502** transforms this opportunity into a reality, making it easy to produce double-sided photo products. The D502 is your way to get into the game and win.

It's a whole new game. Will you be a **spectator** or a **player?**

Introducing the Noritsu D502 Duplex Inkjet Photo Printer

Onsite and on target. The Noritsu D502 is the perfect double-sided inkjet printer designed to meet the rapidly growing demand for photo books, greeting cards, calendars, posters, scrapbooks and enlargements. Satisfy the demand and make a customer for life.

For all types of businesses

- Photo retailers
- Professional photographers
- Business printers

Photo Books

- Hard and soft cover output
- 6"x 6", 8"x 8", 10"x 8", 8.5"x 11"

Greeting cards and post cards

- 4"x 6" and 4"x 8" single-sided
- 4"x 6" and 4"x 8" double-sided
- 5"x 7" double-sided pre-scored folded

Photo calendars

- Desktop and wall calendars
- Spiral bound ready

Business cards

- Single-sided
- Double-sided

Standard prints

- 4"x 6", 4"x 8", 8"x 10"
- Single and double-sided

Perfect for all types of uses

- High quality, short run books
- Commercial portfolios
- Business presentations
- Direct mail

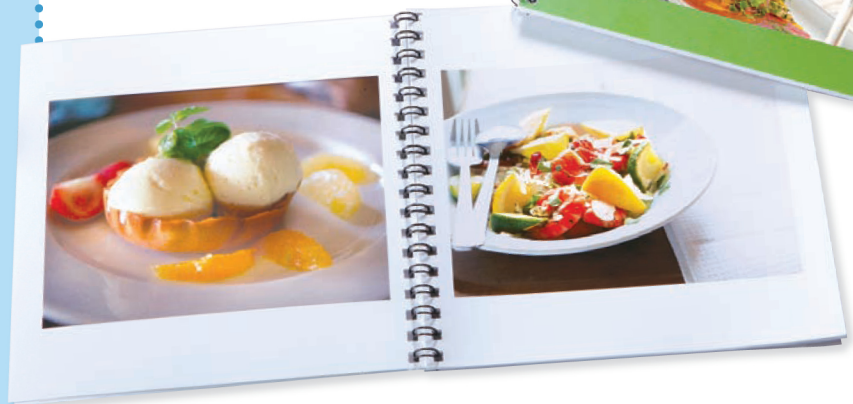
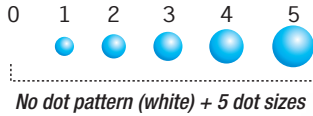

Photo quality prints:

6th generation inkjet technology - 6 gradations per dot

- Revolutionary 4-color dye ink
- Full 720x720 dpi high-quality resolution
- Glossy and semi-glossy finishes
- Long lasting and fade resistant



6 gradations per dot

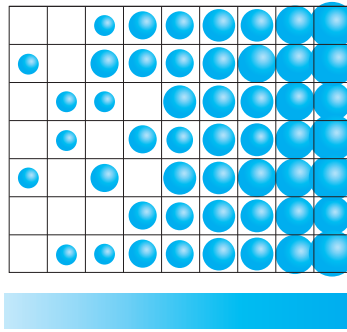

Fine gradations resulting in photos with smooth color tones

Molecular structure of conventional dye ink

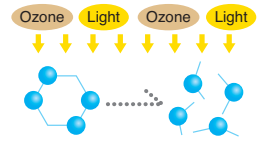

Molecular structure of D502 ink

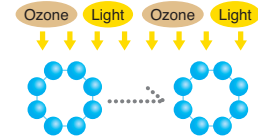

The improved D502 dye ink withstands the effects of light and ozone, resulting in extended print life

Small footprint:

Compact and flexible

- 3.6 square feet
- Designed for tight spaces



Compact printing solution:

Optional cabinet combines D502 and Noritsu NPB-1 Soft Cover Photo Book Binding system into one compact solution

- Great results for soft cover photo books
- The D502 is also designed to work with other binding systems



Easy training and operation:

Sheet paper magazine system

- Paper cartridges make it easy to switch paper sizes and finishes

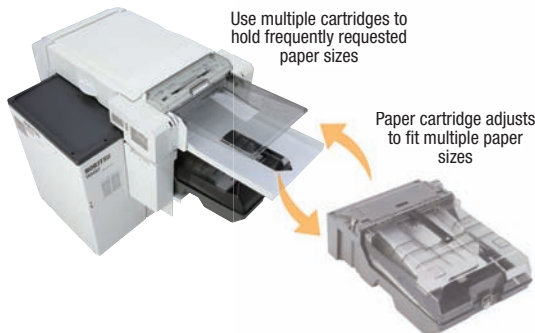

Dry printing

- Simply pull out the empty ink cartridge and insert a new 500 ml cartridge
- Internal 50 ml reservoir prevents interruptions in printing when changing inks



Easy soft cover photo book binding with the Noritsu Photo Book Binding System (NPB-1)

Creasing

- Create clean folds for a professional look



Binding

- Easy, no mess binder heats and seals the glue



Cutting

- The cutter quickly and safely trims the bound book



The digital equation is changing...again.

First, it was digital cameras. Now, it's photo books and other dual-sided, personalized products. The consumer is still in the driver's seat and it's up to all of us to jump on board to satisfy their demands.

The opportunity is **2x**

- With a duplex printer, you can give your customers what they want without giving away the store. In fact, it's a very profitable equation.

The numbers are pointing to many more customers coming to your store

- In a survey focused on photo book ordering conducted by the Photographic Marketing Association in 2009
 - Online photo book ordering is declining
 - At home printing of photo books is declining
 - **Photo book orders in stores are INCREASING!**

They're coming to your store for duplex printing. They want your guidance and help. It's your opportunity to make sure they keep coming back.

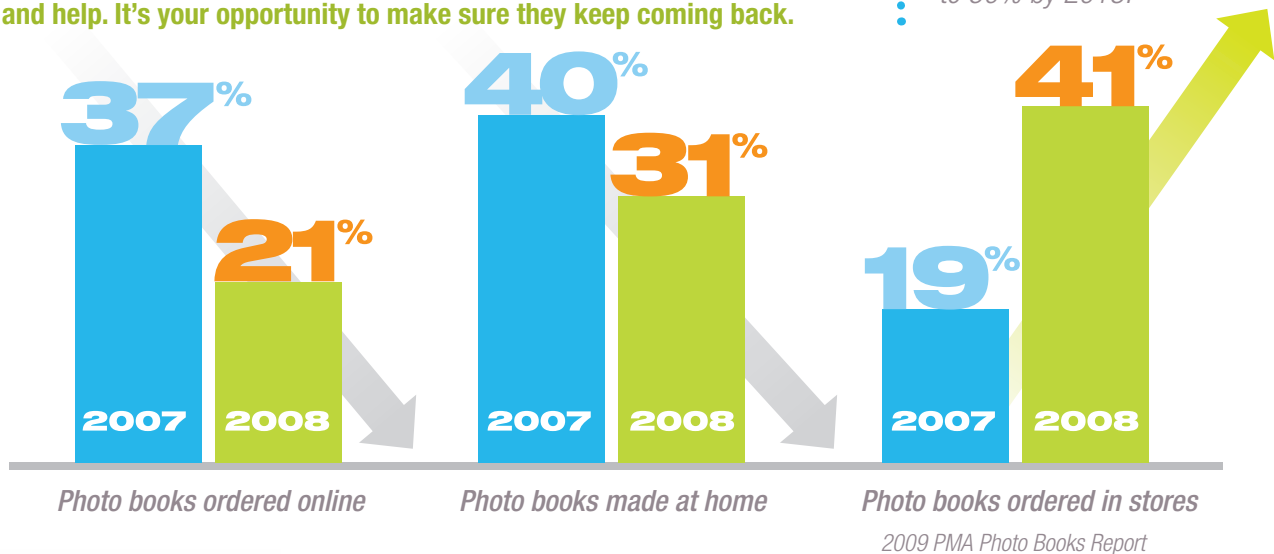

38%

Growth rate

According to a recent InfoTrends study, photo merchandise will experience explosive growth this year, reaching \$2.5 billion by 2013.

42%

are photo books!

42% of the growth rate is attributed to photo books. And it's projected to grow up to 50% by 2013.



The Noritsu Promise. Quality. Performance. Innovation. Value. And above all, service. It's what we're known for. It's our commitment. Our passion. And it's our promise to you, our customer.

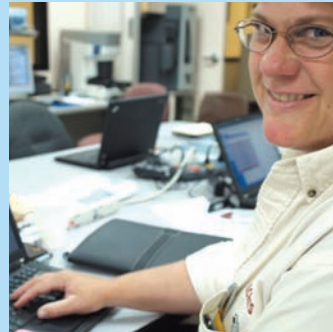
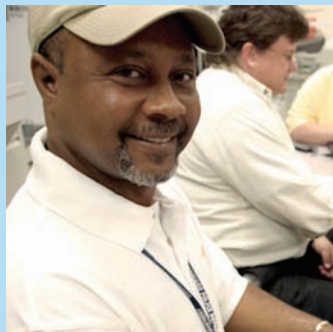
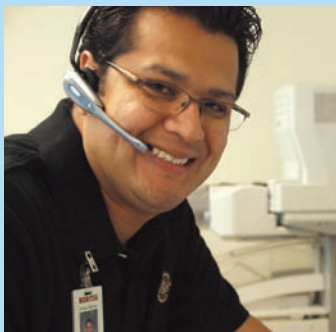

The Noritsu D502 received the 2009 Digital Imaging Marketing Association Vision Award for showing innovative thinking in pushing technology to advance the digital imaging industry.

D502 system specifications

D502 Duplex Inkjet Printer	
Printing system	Inkjet system
Print resolution	720x720dpi
Paper advance length	When using sheet paper magazine: 5.8"-14.5" When using print tray*1: 5.8"-24"
Paper types	Single-sided sheet paper (Glossy) 4"x6", 8"x10", A4 Single-sided sheet paper (Semi-glossy) 8"x10", A4 Double-sided sheet paper (Thin, Semi-glossy) 6"x6", 8"x8", 10"x8", A4, 8.5"x11 Double-sided sheet paper (Thick, Semi-glossy) 4"x6", 4"x8", A4, 8.5"x11" Double-sided sheet paper (Thick, Folded, Semi-glossy) 10"x7" Single-sided sheet paper (Photo book cover) 6"x13", 10"x17", 10"x24"
Ink	4 colors of dye ink: Y (Yellow), M (Magenta), C (Cyan), BK (Black) Volume: 500ml per color
Dimensions	See "External view" below
Weight	Printer with the Reverse Unit: 255 lbs (excluding RIP-PC, options, paper and ink cartridges)
Power specifications	AC100-120V / 200-240V 1P2W (Not including RIP-PC)
Rated power capacity	800VA or less (Not including RIP-PC)

Repeat print capacity prints per hour		
Print size	Capacity (Approx.)	
	Single-sided prints	Double-sided prints
4"x 6 "	450	180
4"x 8 "	370	150
6"x 6 "	410	160
8"x 8 "	290	110
10"x 7"	300	110
10"x 8"	270	100
A4 size	210	70
Letter size/8.5"x11"	220	71

Calculated according to our criteria. The capacity you achieve may be different.

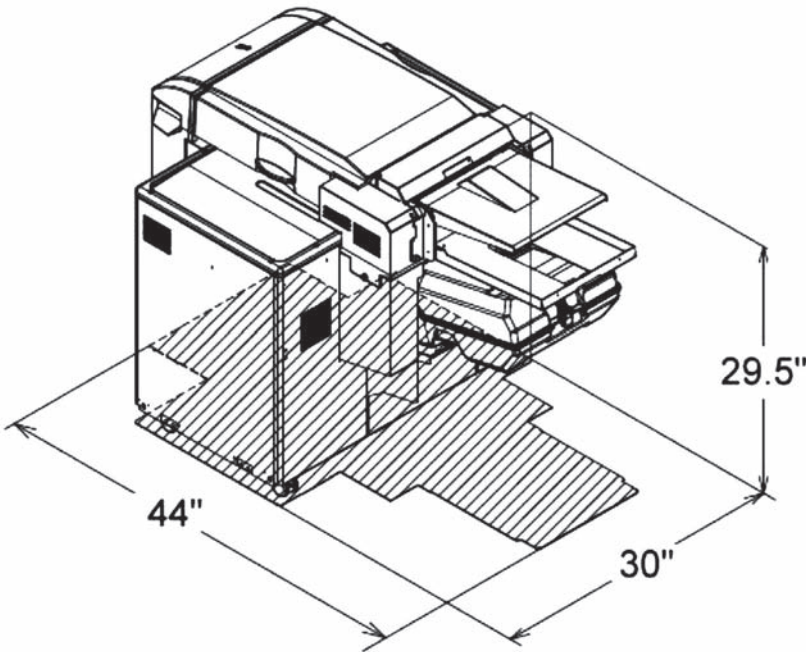

Noritsu Photo Book Binding System NPB-1		
	NPB-1CR	NPB-1BD
Binding method	Hot-melt adhesive perfect binding	
Maximum binding width (Maximum length of spine)	12.6"	
Maximum cover length	25.6"	
Minimum length of photo book	4.7"	
Binding thickness	0.12"-0.47" <Reference> 0.12" thick: Photo book with 24 pages (12 sheets) 0.47" thick: Photo book with 98 pages (49 sheets) Paper thickness: Cover 288µm, Inner pages 222µm	
Dimensions	W20.9"xL18.9"xH7.3"	W21.1"xL11.8"xH12.2"
Weight	27.5 lbs	31.9 lbs
Power specifications	For regions that use 100V, 115V AC100V, 115V 1P2W For regions that use 220-240V AC220-240V 1P2W	
Rated power capacity	700VA or less	
Cutting method	Guillotine cutter	
Maximum cutting width (Width of paper that can be set in cutter)	12.6"	
Maximum cutting thickness	0.47"	
Trimming Length (Length of paper edge that is cut off)	0.12"-2.4"	
Minimum size photo book can be cut to	4.7"x4.7"	
Dimensions	W17.8"xL22.4"xH15.8"	
Weight	92.4 lbs	
Power specifications	For regions that use 100V AC100V 1P2W For regions that use 115V AC115V 1P2W For regions that use 220-240V AC220-240V 1P2W	
Rated power capacity	250VA or less	

D502 Accessory Software	
	EZ Controller
	QSS Printer Driver (XP,Vista)
	Express Digital Darkroom Pro Edition
	GraphX Raster Plus
	Noritsu Quick Access

© 2009 Noritsu America Corporation. The information contained herein is subject to change without notice. Noritsu shall not be held liable for technical or editorial errors or omissions contained herein. D502 is a trademark or registered trademark of Noritsu. All other brand names, product names, or trademarks herein belong to their respective holders.

*Specifications subject to change without notice.

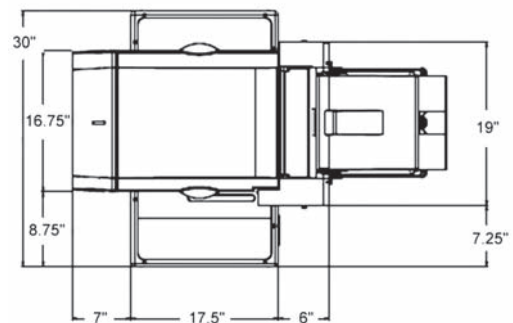

Call today for a free system consultation - Our consultants will be happy to customize the right solution and leverage your existing equipment investment for your business needs.

NORITSU
www.noritsu.com/D502
(800) 521-3686 x 219

Noritsu America Corporation
6900 Noritsu Avenue
Buena Park, California 90620-1372

Eastern Regional Office
336 Route 46 East
Fairfield, New Jersey 07004-2429

Noritsu Canada Ltd.
2680 Argenta Road
Mississauga, Ontario, Canada, L5N 5V4



Our products have been manufactured under an ISO 9001-certified quality assurance system.

CAT#D502 10/09